

SPIROTRAP® INSTALLATION and OPERATION INSTRUCTIONS *DIRT SEPARATOR MODELS TDT/TDN and THT/THN*



SAFETY INSTRUCTION

This safety alert symbol will be used to draw your attention to safety related instructions. When used, this symbol means Attention! Your safety is involved! Become Alert! Failure to follow these instructions could result in a safety hazard!

INSTALLATION INSTRUCTIONS

It is recommended that the Spirotrap Dirt and Drain Models be installed upstream of the system components that are affected by the dirt in the system. (Please refer to Figures 1 & 2 below). It does not take the place of a system strainer and should be installed after that component to ensure no large construction type debris enters the unit. Please note that Spirotrap units must be mounted in a straight run of horizontal piping.

The piping normally supports the weight of the Spirotrap Dirt and Drain models up to and including 12". Support legs recommended for units 14" and larger. "X" pipe diameters of straight run before and after the unit are not required.

The flow may be directed to either side of the unit. There is NO directional arrow. Either connection may be used for inlet or outlet.

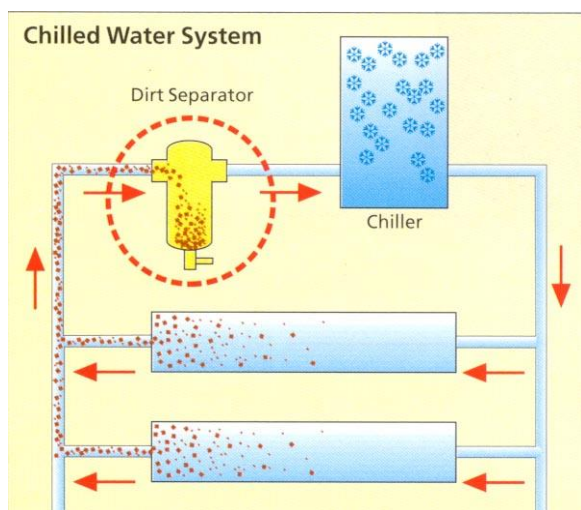

Figure 1

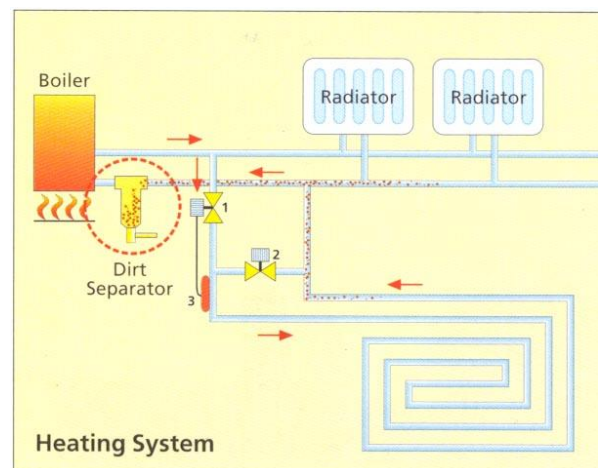



Figure 2

SERVICE INSTRUCTIONS

The Spirotrap does not normally require maintenance and includes no moving parts other than the manual ball valve or optional user-installed automatic valve.

The Spirotrap Dirt and Drain Models are designed for dirt and sediment separation. The ball valve on the bottom of the unit should be opened on a regular basis to purge debris from the collection chamber. A container should be used to catch any debris.

 **WARNING! Water Temperatures above 100°F can be very hazardous. Keep body away from connection while open. Failure to follow these instructions may cause serious bodily injury or property damage.**

Frequency of purging is system dependent based upon degree of sediment in the system. Frequent purging is recommended right after installation and then scheduled as needed as the systems clears.

Units with optional removable head can be disassembled and the tube bundle removed for inspection or cleaning. The removable head is a user-specified feature and frequency of inspection and/or cleaning is user or system dependent.

 **WARNING! System fluid under pressure can be very hazardous. Before removing the unit head, reduce system pressure to zero, or isolate the Spirotrap from the system. Allow the system to cool to below 100°F. Failure to follow these instructions may cause serious bodily injury or property damage.**

 **WARNING! Unit head and bundle are heavy. Keep body clear of the head and bundle when disassembling. Failure to follow these instructions may cause serious bodily injury or property damage.**

Taking care to support the head, remove bolts and slide the bundle out. Clean the bundle using a pressure washer or hose and reinstall the bundle in the Spirotrap unit. Be sure to check the gasket before reinstalling the head, and replace if necessary. Tighten bolts using a criss-cross pattern to proper torque. Before opening isolation valves, close ball valve.