

SPIROTHERM®

SPIROVENT® INSTALLATION and OPERATION INSTRUCTIONS *Junior Series VDR Air Eliminator & Dirt Separator*

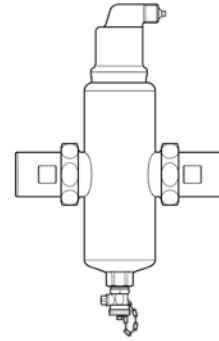

This safety alert symbol will be used to draw your attention to safety related instructions. When used, this symbol means **Attention! Your safety is involved! Become Alert!** Failure to follow these instructions could result in a safety hazard!

INSTALLATION INSTRUCTIONS

The Spirovent Junior VDR Air Eliminator / Dirt Separator should be installed at the point of lowest solubility in the system: that being where the temperature is the highest (i.e. after the boiler and/or heat exchanger) and the pressure is the lowest (i.e. before the pump suction), as pictured below. As with all hydronic system piping it is recommended to have the expansion tank connection to the system on the suction side of the pump or circulator.

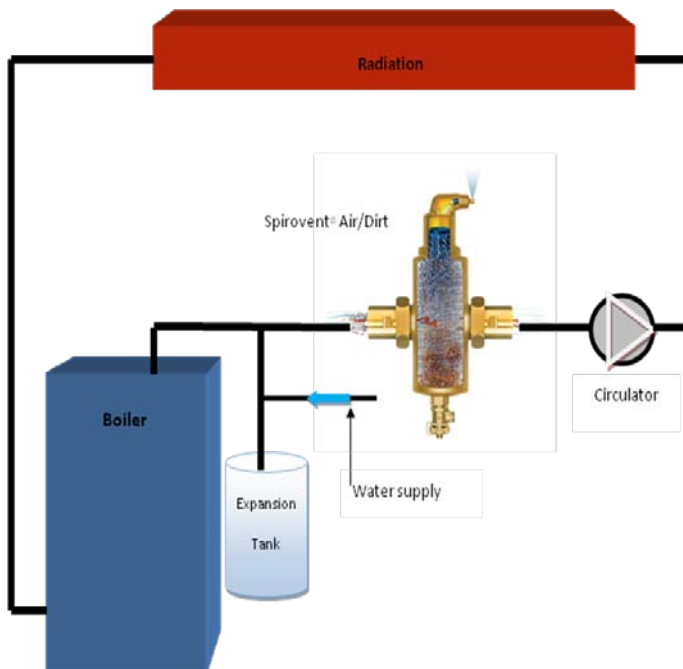

VDR models must be mounted in a straight run of horizontal piping in a perfectly upright position to allow the vent to operate freely. "X" pipe diameters of straight run before and after the unit are not required.

The flow may be directed to either side of the unit. There is NO directional arrow. Either connection may be used for inlet or outlet.

The threaded connection at the air vent outlet has been provided as a convenience for those wanting to pressure test the system with air prior to filling. To test, install a ½" pipe cap before filling and remove the cap once testing is complete.

During operation, this threaded connection should be free of any piping connection with the unit in service to allow the free flow of air and gases. It may be piped to another location if left open, however, the risk then exists for blockages, which will impede the product's performance.

CAUTION! Do not attempt to turn the venting port, as that will damage and/or destroy the venting mechanism.

⚠ WARNING! Water temperatures above 100°F can be very hazardous. Keep body away from valve while open. Failure to follow these instructions may cause serious bodily injury or property damage.

SERVICE INSTRUCTIONS

The VDR does not normally require maintenance and includes no moving parts other than those in the vent head itself. The lower chamber is designed for dirt and sediment separation. The ball valve on the bottom of the unit should be opened on a regular basis to purge debris from the collection chamber. Use the square head on valve cap as the key. A container should be used to catch any debris.

⚠ WARNING! System fluid under pressure can be very hazardous. Before removing the vent head for inspection, reduce system pressure to zero, or isolate the Spirovent from the system. Allow the system to cool to below 100°F. Failure to follow these instructions may cause serious bodily injury or property damage.

1. Using two strap wrenches, hold the body in place in the piping while removing the vent head, taking care not to damage the O-ring. Pipe wrenches may be used, but they can leave marks in the brass.
2. To clean the vent head, use a mild detergent and water or vinegar and water solution. For extremely dirty conditions, soak the head in mineral spirits for several hours and then clean thoroughly. The vent head is available as a replacement part if necessary. Use part number PJR000HA. Assembly includes the O-ring.
3. While the vent head is removed, remove the coalescing medium from the body and rinse thoroughly with mild detergent and water or vinegar and water to remove any system contaminants.
4. Examine O-ring before installing on the Spirovent and replace if necessary. Use part number PJR000RG.
5. Reassemble the Spirovent.
6. Return system to operating condition.

⚠ WARNING! Water temperatures above 100°F can be very hazardous. Keep body away from valve while open. Failure to follow these instructions may cause serious bodily injury or property damage.

7. If system was completely drained, minimal manual bleeding may be required at the highest points to ensure the system is completely full of water and able to circulate.

SPIRO THERM
A Spiro Enterprises Company

Spirotherm, Inc.
25 N. Brandon Drive
Glendale Heights, IL 60139

630-307-2662
Fax: 630-307-3773

Website: www.spirotherm.com
E-mail: info@spirotherm.com

© 2012 Spirotherm, Inc.

VDR-IOM-A