

Spirovent® Dirt 14", 16", 18", 20" Air Eliminator and Dirt Separator

Job Name:
Engineer:
Contractor:
Representative:

Tag	Model	Flow	Size	Location

Specifications:

Shell	Steel
Vent Head	Brass
Float	Non-Ferrous
Seal	Viton
O Ring	Viton
Skim Valve	Brass
Coalescing Medium	Copper
Ball Valve	Brass
Max. Working Pressure	150 psig
Max. Operating Temperature	270°F

Pipe Size	14"	16"	18"	20"	
D (inches)	28	32	36	40	
H2 (inches)	98	110	122	134	
h2 (inches)	43	49	55	61	
LF (inches)	45	50	56	61.4	
hs (inches)	20	22	22	26	
e (inches)	2	2	2	2	
Dry Weight (lbs)	1,320	1,810	2,370	3,640	
Volume (gallons)	205	310	440	610	
Rec. Flow (gpm)	2,530	3,300	4,180	5,200	
Model	VDT----FA	1400	1600	1800	2000

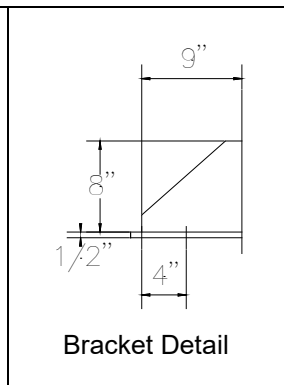
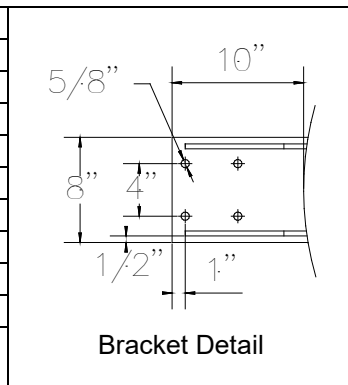

(Dimensions for reference only)

Flanged ASME Section VIII, Division 1 Stamped and Registered