

**Spirotrap® Drain
30", 36" Dirt Separator**

Job Name:
Engineer:
Contractor:
Representative:

Tag	Model	Flow	Size	Location

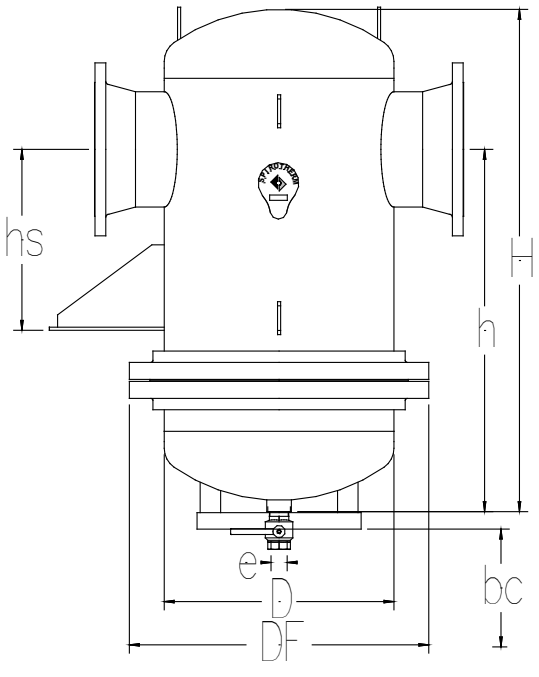

Specifications:

Shell	Steel
Coalescing Medium	Copper
Ball Valve	Brass
Max. Working Pressure	150 psig
Max. Operating Temperature	270°F

Notes:
Removable lower portion to facilitate cleaning if required.
(bc: Minimum bundle removal clearance)

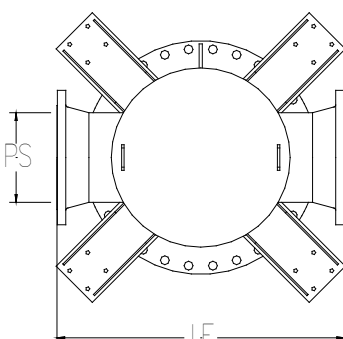

PS - Pipe Size	30"	36"
D (inches)	60	72
H (inches)	129	154
h (inches)	92	109
LF (inches)	86	103
DF (inches)	73	87
hs (inches)	30	36
e (inches)	2	2
bc (inches)	88	99
Dry Weight (lbs)	9,410	14,590
Volume (gallons)	1,430	2,460
Rec Flow (gpm)	12,100	17,400
Model	TDN----FA 3000	3600

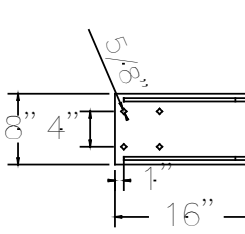

Bracket Detail

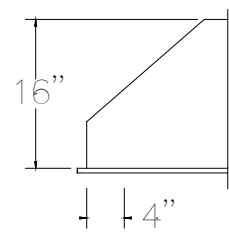

Bracket Detail

(Dimensions for reference only)

Flanged. ASME Section VIII, Division 1 Stamped and Registered