

Spirovent® Dirt
20", 24", 30" High Velocity Air Eliminator and Dirt Separator

Job Name:
Engineer:
Contractor:
Representative:

Tag	Model	Flow	Size	Location

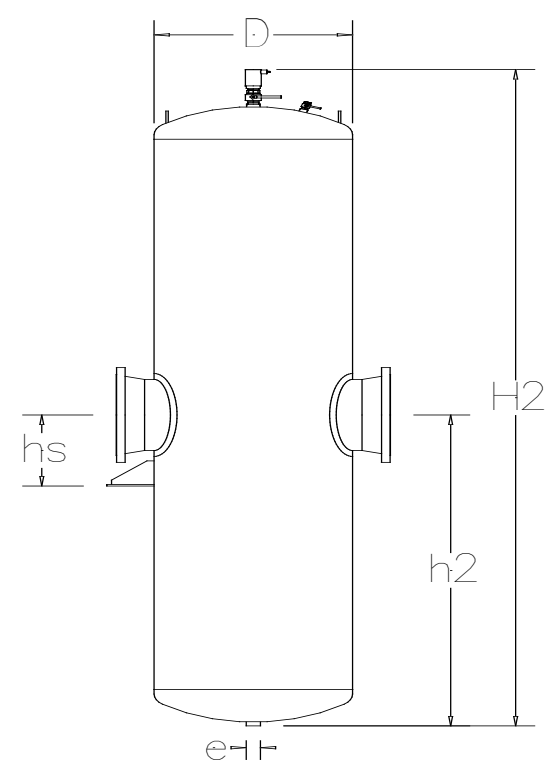

Specifications:

Shell	Steel
Vent Head	Brass
Float	Non-Ferrous
Seal	Viton
O Ring	Viton
Skim Valve	Brass
Coalescing Medium	Copper
Ball Valve	Brass
Max. Working Pressure	150 psig
Max. Operating Temperature	270°F

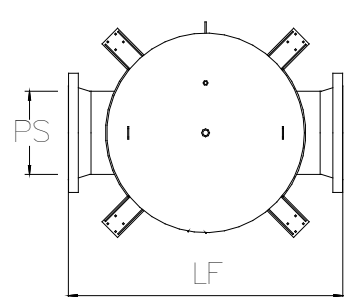

Pipe Size	20"	24"	30"
D (inches)	48	60	72
H2 (inches)	142	156	204
h2 (inches)	65	72	96
LF (inches)	72	84	108
hs (inches)	26	26	30
e (inches)	2	2	2
Dry Weight (lbs)	4,400	5,900	12,000
Volume (gallons)	925	1,600	3,100
Max. Flow (gpm)	8,650	12,500	20,200
Model			
VHT----FA	2000	2400	3000

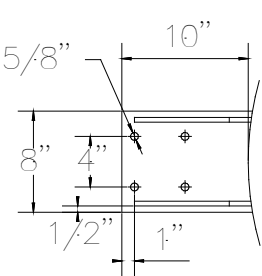

Bracket Detail

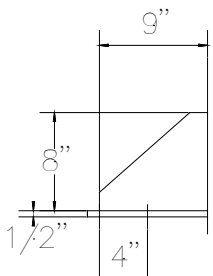

Bracket Detail

(Dimensions for reference only)

Flanged ASME Section VIII, Division 1 Stamped and Registered